

PRODUCT DATA SHEET

RKA-SS4.2G15E-F33 - 1750 RPM

DESCRIPTION

In high frequency and long time operation, high accurate manufacturing technique is the only answer to the durable reputation Annovi Reverberi pumps. The S.S. Series uses include various applications such as reverse osmosis water desalination, seal gland flushing and waste water odor control. S.S. Series feature a SAE 316 stainless steel manifold this is totally corrosion-resistance. Special pumps features include our highly concentric bearing positioning on both sides of the crankcase, anticorrosion coated aluminum die cast crankcase, continuously lubricated Viton seals, triple lip loaded oils seals and our ultra thick ceramic plungers that will not crack under extreme variable temperature conditions.

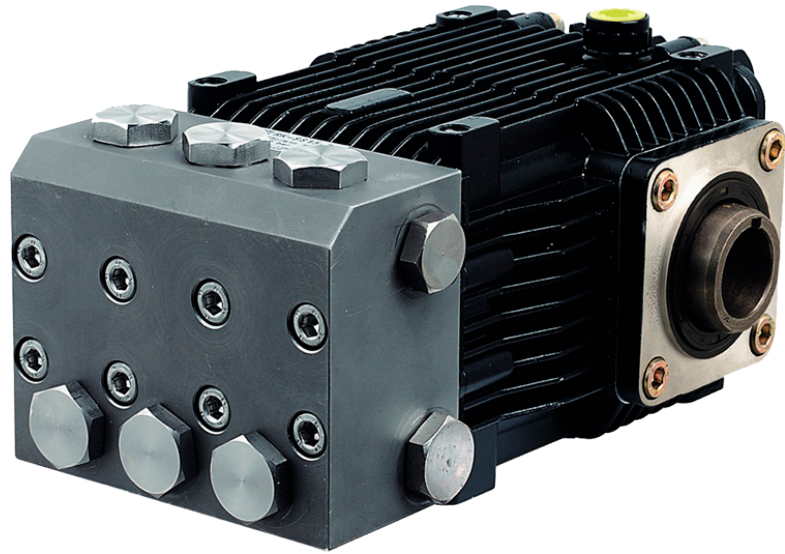

SPECIFICATIONS

MAX GPM	4.2	MAX LMP	15.9
MAX PSI.....	1500	MAX BAR	105
POWER EBHP	4.3	BORE DIA. MM.....	18
STROKE MM.....	12	WEIGHT LBS.....	22
MAX TEMP	140°	OIL CAPACITY.....	15oz
INLET THREAD	1/2" F	DISCHARGE THREAD	3/8" F

DIMENSIONS

RKA-SS E version + F33
Hollow shaft pump \varnothing 5/8"

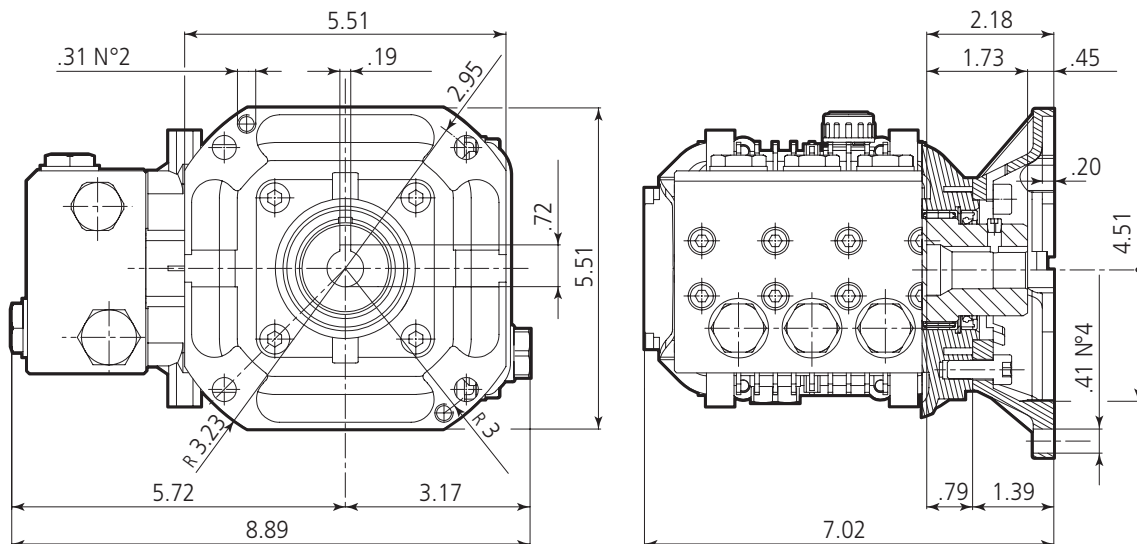

SPECIAL FEATURES

WET END

- **Manifold:**
 - **316L - Stainless Steel Block Style:** Strength and no porosity = long life.
 - **Inlet and Discharge Ports:** 1/2" inlet and 3/8" discharge.
 - **Offset Discharge Ports:** High efficiency, smooth flow
 - **Bolts:** 8 Bolts, 6mm, stainless steel.
- **Valves:**
 - **Ultra Form Cages:** Durable, strength, and long life.
 - **Poppets, Seat and Spring:** 316 series stainless steel.
 - **Valve Caps:** Machined 316L series stainless steel.
- **Packing and Plungers:**
 - **High Pressure Packing:** "V" style (D-1) Viton (cotton duct weave base) strong and tightens under load.
 - **Low Pressure Seals:** "U" cup double lip Viton, good positive seal.
 - **Support and Guides:** Machined stainless steel, 2-piece construction and special back-up ring to assure proper plunger alignment, maximize packing and seal life.
 - **Plungers:** Special aluminum oxide blend, solid ceramic long life, strong and durable ultra thick design.

DRIVE END

- **Bearings:** Premium oversized taper for maximum life and load dispersement.
- **Bearings Supports:** Precision die-cast and machined to assure concentricity and alignment.
- **Crankcase:** Precision die-cast, large cooling fins and covered with a special anti-corrosion finish.
- **Rear Cover:** Precision die-cast, O-Ring sealed and bayonet style sight glass for positive sealing and locking (no threads to loosen). This is an "AR" original. Oil drain plug.
- **Plunger Rods:** Stainless steel construction for strength, back-up and O-ring plunger sealing

system. Special acorn style retaining nuts and SST slingers.

- **Rod Pins:** Precision ground and hardened steel, oversized for load dispersement.
- **Connection Rods:** 1-piece special allow bronze for higher pressures, oversized for maximum strength, load dispersement, and life. Heavy pin area construction.
- **Crankshaft:** Forged, precision ground and hardened for extremely long life and durability. Available in 24mm solid shaft, 5/8" and 1-1/8" hollow shafts, hydraulic motor and gearbox drives. Shaft key set screws are standard on high-speed version for long shaft life.
- **Oil Seals and O-Rings:** Triple lip oil seals, long life and much less leak prone. All are constructed of Buna-N rubber. The O-Rings have stainless steel garder springs for assure constant tension on the sealing surface.
- **Oil Drains:** Quantity of 2. One in the rear cover and one in the bottom of the crankcase.
- **Oil Capacity:** 15 oz.
- **Oil Sight Glasses:** Rear cover and non-drive side bearing housing.

EXTRA FEATURES

- **Dyno Proven:** All pumps are dyno tested to assure the theoretical design meets the actual design.
- **Valve Design:** Each pump series has a valve design that optimizes its highest efficiency.
- **Hot Water:** High temperature kits are available to 180°F.
- **Wet End Repair:** Very simple no special tools are required.
- **Mounting Flanges:** Multiple flanges are available.
- **Buna-N:** Elastomers available.